

Suggested maximum 4 in. w.g. differential pressure

STANDARD MATERIALS AND CONSTRUCTION

- FRAME:** 16 GA. galvanized steel, 7½" deep.
- BLADE:** 16 GA. galvanized steel, reinforced for frames over 18" dia.
- SHAFT:** ½" dia. Cadmium plated steel stub.
- BEARINGS:** Flange Oilite Bronze.
- SEALS:** On frame, ¼" thick closed cell neoprene. Temperature range is -35°F to 180°F.
- CONTROL ROD:** Cadmium plated steel.
- FINISH:** Mill.

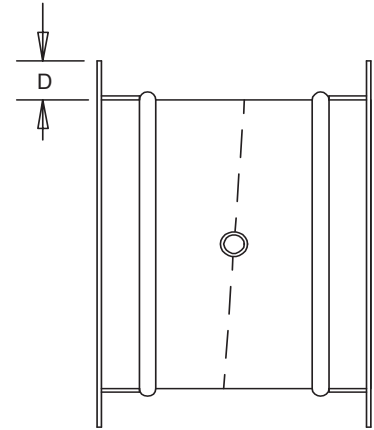

Equal Leg Angles are available. They are welded to frames at intermittent spacing and caulked between welds. Flange Height "D" varies with Damper Diameter.

NOTES

1. Dampers are available in 1" increments only.
2. Please contact the factory for damper sizes larger than 36" diameter.
3. To calculate approximate shipping weight (lbs./in.), use following formula:
 Damper Circumference (Diameter [in.] × 3.141) × 0.5

DAMPER SIZES

Minimum Size	Maximum Size
4" O.D.	36" O.D.

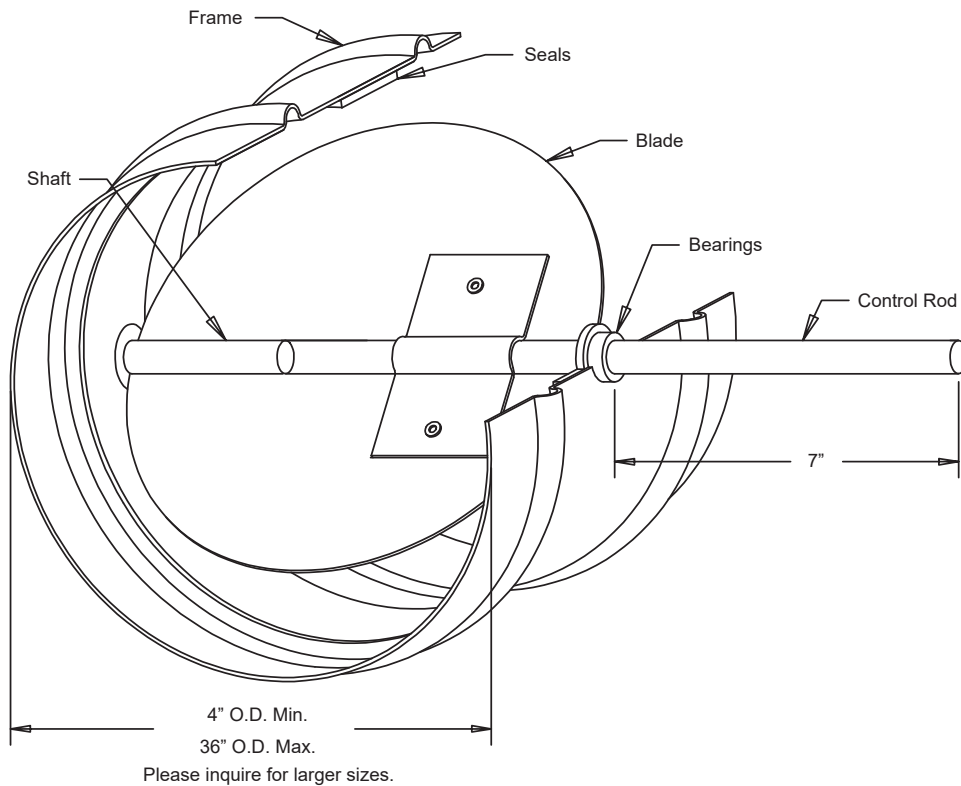

Please inquire for larger sizes.

Item #	Qty	Damper Size O.D.	Tagging	Remarks	 Union Made
Arch. / Eng.:			EDR:	ECN:	
Contractor:					
Project:			Date:	DWN:	DWG:

PRESSURE DROP RATINGS

Pressure Drop Ratings are based on AMCA Standard 500 using test set-up 5.3 for Dampers installed with Duct Upstream and Downstream. Static Pressures are corrected to 0.075 lb./cu.ft. air density.

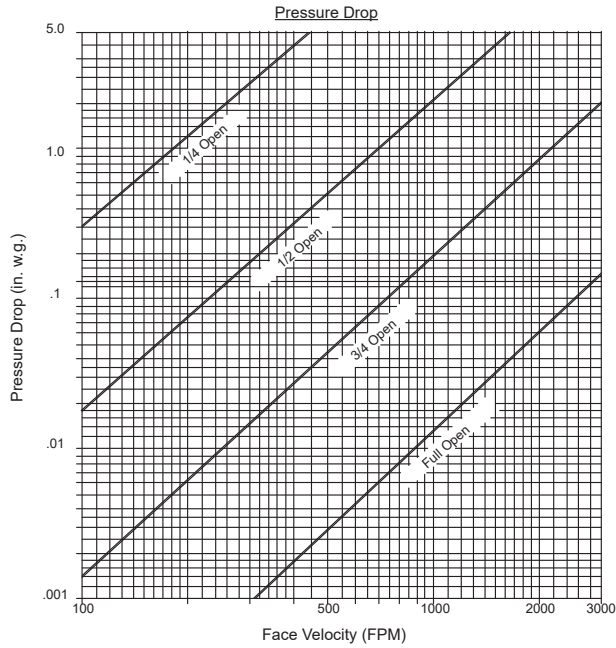

AIR LEAKAGE RATINGS

Air Leakage Ratings are based on AMCA Standard 500 using test set-up 5.4. Air Leakage is corrected to 0.075 lb./cu.ft. air density.

